

Full length article

IoT-enabled smart appliances under industry 4.0: A case study

Shohin Aheleroff^{a,*}, Xun Xu^a, Yuqian Lu^a, Mauricio Aristizabal^b, Juan Pablo Velásquez^b, Benjamin Joa^b, Yesid Valencia^b

^a Department of Mechanical Engineering, The University of Auckland, New Zealand

^b NetuxLAB, Medellín, Antioquia, Colombia



ARTICLE INFO

Keywords:

Industry 4.0
Internet of Things
Big data analytics
Smart products

ABSTRACT

Manufacturers expect the extra value of Industry 4.0 as the world is experiencing digital transformation. Studies have proved the potential of the Internet of Things (IoT) for reducing cost, improving efficiency, quality, and achieving data-oriented predictive maintenance services. Collecting a wide range of real-time data from products and the environment requires smart sensors, reliable communications, and seamless integration. IoT, as a critical Industry 4.0 enabler emerges smart home appliances for higher customer satisfaction, energy efficiency, personalisation, and advanced Big data analytics. However, established factories with limited resources are facing challenges to change the longstanding production lines and meet customer's requirements. This study aims to fulfil the gaps by transforming conventional home appliances to IoT-enabled smart systems with the ability to integrate into a smart home system. An industry-led case study demonstrates how to turn conventional appliances to smart products and systems (SPS) by utilising the state-of-the-art Industry 4.0 technologies.

1. Introduction

Huge demand and industrial competition have encouraged most industries to move beyond mass production. Mass personalisation requirements can be better fulfilled by utilising some of the Industry 4.0 technologies. In the ever-growing personalisation paradigm, smart products can provide a response to individual customers in the Industry 4.0 era. However, people are using conventional appliances regularly while demanding smart products. For a steady demand and supply, it is necessary to make changes with a less negative impact on established production lines. Smart appliances initiate broader systems, such as smart home and smart building systems, to consequently achieve smart cities. Conventional homes are reforming into smart homes since Industry 4.0 emerged. Fig. 1 shows the transition of a conventional home appliance (No.1) toward a portfolio of smart systems end up to a smart city (No.5) for meeting the United Nation Agenda for sustainable development [1]. IoT has a high potential for real-time data collection, providing meaningful information, predictive maintenance at low cost while opening up a new frontier of a data-driven approach for generating extra value. A wide range of sensors connected through IoT can provide personalised services by using Big data analytics [2]. As significant benefits are obtained from smart devices, factories are willing to take digital transformation by adopting IoT for the three main reasons, including energy efficacy, personalisation, and advanced

predictive maintenance. Ripping the full benefits of Industry 4.0 requires fitting infrastructure, which poses more challenges for developing countries. Manufacturing in these countries is often the backbone of their economy. One of the largest industries is home appliances manufacturing. First, it is challenging to identify essential data, sensors, actuators, and integration of advanced technologies in a traditional production line. Second, it is crucial for smart appliance manufacturing to utilise an IoT platform for enriching data to valuable information and knowledge [3]. Third, academia has difficulties in providing real-world IoT-enabled industry-led experiments for next smart home systems.

Industry 4.0 enables appliances to bring benefits, including personalisation, prediction, energy saving, reducing defects, and quality improvement [4]. IoT connects things and presents characteristics such as heterogeneity, enormous scale, sensing, location awareness, and personalisation. The convergence of intelligence and real-time connection make smart systems, which in most cases have equipped with edge computing and IoT to access Cloud services. IoT enables seamless integration between sensors and Cloud for further predictive maintenance via big data analytics [5]. The combination of physical things, a wide range of networks, IoT, big data, artificial intelligence (AI), Cloud capacity and process gives rise to smart systems. The intelligence and connectivity over IoT fulfil the four main functionalities consist of real-time monitoring, controlling, optimisation, and autonomy. IoT provides a monitoring dashboard and notification system as an immediate and

* Corresponding author.

E-mail address: shohin.aheleroff@auckland.ac.nz (S. Aheleroff).

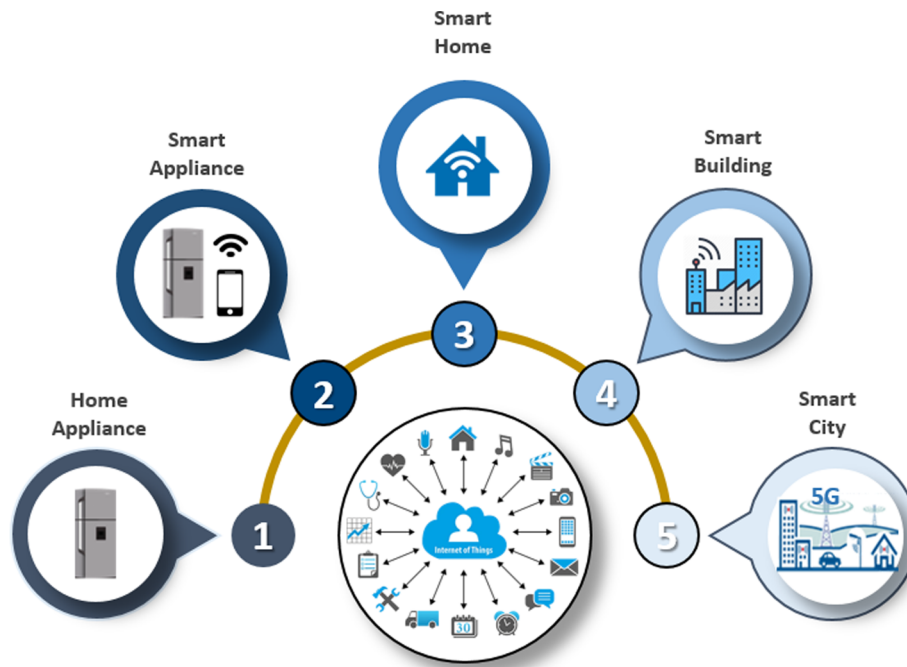

Fig. 1. IoT enabled portfolio toward digital transformation.

direct benefit to smart systems. IoT enables transforming data to information, knowledge and wisdom (DIKW) for real-time monitoring, notification, and predictive maintenance at the product and service level in a smart environment [6]. This paper reports on an industry-led case study on transforming a typical appliance into a smart and IoT-enabled appliance with an effort to answer the following four research questions.

- How to transform conventional home appliances to smart devices?
- How to address seamless integration over a secure network connection?
- How to empower users with real-time monitoring and controlling of home appliances?
- What technologies are required for making conventional appliances smart?

The remaining sections are organised as follows. Section 2 reviews related works regarding Industry 4.0, IoT, big data, smart products, and IoT based frameworks and platforms. Section 3 concentrates on the case study consist of Design, Network connections; Edge computing, Architecture, IoT Platform, Development, and Validation. Key challenges including deployment, operations, multi-vendor integration, and suggestions, are discussed in Section 4. Section 5 concludes this study by giving key contributions and future perspectives for the next generation of smart appliances.

2. Literature review

IoT transforms the traditional business into a digital paradigm by increasing real-time connectivity, data-gathering and analytics capabilities. Therefore, data become a source of value to leverage customers for demanding affordable SPS with a higher degree of personalisation than ever [7]. Since IoT started gaining attention in the early 2010s, the home appliance sector is one of the pioneer industries that is using cutting-edge technologies, including IoT and Cloud [8]. Sensing, actuating, and real-time data transmission capabilities are enabled by IoT through a seamless collaboration [9,10]. The critical advantage of IoT relies on enabling massive data processing by applying big data

analytics [11]. IoT enables real-time data exchange among a large variety of sensors for different applications, such as road-intersection, traffic-flow, monitoring, and managing pollution, which are essential for smart cities [12]. The evolution of IoT-enabled smart homes is empowered via a different network connection, such as Bluetooth and GSM for monitoring and controlling home appliances remotely. SPS is using wireless technology, such as Wi-Fi (IEEE 802.11), Radio Frequency Identification (RFID), Bluetooth (IEEE 802.15.1), ZigBee, IPv6 Low-Power Wireless Personal Area Network (6LoWPAN), and cellular systems.

Collected data from individual smart appliances are used across a smart city for energy efficiency [13]. A smart home system can optimise power consumption and reduce costs while maintaining consumer satisfaction [14]. Furthermore, users can enable natural voice to manage smart home appliances by using a digital assistant, such as Amazon Alexa, Google Home, Apple Siri, and Microsoft Cortana [15]. IoT has a significant potential to build the foundation for the next SPS generation [16]. The value proposition of IoT empowers affordable personalisation through data-oriented systems [17]. Data from connected things has to be enriched with big data analytics to generate meaningful information into a smart level [18,19].

Conceptual Industry 4.0 frameworks were proposed for promising technologies in a wide range of industries. Due to specific necessities, researchers have proposed suitable connection-oriented frameworks, such as smart home architecture [20], healthcare IoT-based framework [21], architecture for smart cities [22–24] framework for smart transportation [25], manufacturing monitoring and diagnosis system framework [20], Cloud-based security and privacy framework [26–28] mobile-enabled framework [29], advanced medicine manufacturing framework [30], digital twin systems architecture and framework [31,32] and framework for large-scale wireless sensor networks [33]. The use of conceptual IoT framework crosses both scale and functionalities in research and development. With the advancement in the Industry 4.0 era, the home appliances industry has utilised technologies such as IoT and big data, which enables incremental data collection from users and smart devices. There is no silver bullet framework that suits every IoT-enabled SPS applications. Therefore, some frameworks and platforms are dedicated to particular industries and applications

using technologies under the Industry 4.0 umbrella. This study discusses IoT-enabled smart home appliances under Industry 4.0. The idea of connecting SPS to the Internet was seen as a revolution in home appliances. The world's first Internet refrigerator was an unsuccessful product because customers had seen it as an unnecessary, expensive, and luxury product. The data-oriented business strategy, consisting of various stakeholders and intelligent systems, continuously strives to reach affordable personalisation [34]. Cost-effective approaches should be introduced for effective data acquisition, knowledge creation and intelligent decision-making concerning SPS [35]. The demand for transferring almost all ordinary appliances to IoT-enabled smart products is increasing. The goal is to develop a complete set of smart appliances by using suitable Industry 4.0 technologies to run into smart appliances including, but not limited to, fridges, washing machines, dishwashers, ovens, dryers, AC systems, and heaters [36]. Although there are signs that affordable personalised appliances are not coming soon, emerging Industry 4.0 technologies have initiated a revolution in smart home applications. The value of manufacturing smart appliances is mostly in utilities, smart cities, and smart grids [37].

The prefabrication and preassembly of home modules, before their shipment and installation on construction sites, create opportunities and threats. An IoT-enabled enterprise resource planning system can benefit the prefabricated home industry in many aspects, such as forecasting, remote monitoring, real-time visibility, alerts and notifications [38]. One of the challenges is to protect free accesses to smart devices in an IoT-enabled system. Due to the insufficient capabilities of IoT devices and security policies, a software-defined security framework for IoT is proposed to address security challenges for a large number of connected devices [39]. Security-oriented IoT frameworks are missing delegation of security management to network protocols to avoid complexity and compatibility in applications, such as smart home systems. IoT enables a variety of sensors at a larger scale to connect and exchange data over Cloud and bring value such as energy efficiency and customer's comfort through personalisation. Therefore, an IoT-enabled framework for data monitoring in restricted areas has been proposed to enrich data and help users within a limited premise, such as a residential building [40].

IoT-enabled frameworks are developed for different industries, mainly advanced manufacturing. Being able to manufacture affordable personalised products is more feasible than ever in Industry 4.0 era. Consequently, to deal with the complexity of cyber-physical systems, an IoT-based collaborative framework has been proposed [41]. While IoT frameworks help advanced manufacturing, other industries and applications are adopting the best IoT practices. For instance, IoT allows small devices with sensing, processing and communication capabilities to understand the environment. Therefore, an IoT-based framework has been proposed for monitoring human biomedical signals [42]. Although some IoT-based frameworks are focusing on mobile applications in healthcare, others like manufacturing are more concentrating IoT capabilities for smart machines and processes. IoT has provided a promising opportunity to build SPS by leveraging the ubiquity of wireless sensors. Subsequently, IoT brings together significant benefits and a series of challenges for data storage and processing from connected things because the data can be generated quite rapidly with huge volume. An IoT-based framework has been introduced to tackle these potential problems [43].

Many IoT frameworks have been proposed for distributed and interconnected systems rather than a customised approach. However, personalisation is a vital feature from an IoT perspective; therefore, a multi-protocol IoT platform has been suggested based on Open-Source frameworks [44]. Particular industries, such as healthcare have unique challenges. For instance, an insufficient workforce may cause a patient in a long waiting list for treatment in a busy hospital. A self-monitoring framework has been suggested to get the benefit of an IoT-based healthcare system to conduct partial treatments at home for measuring pulse rate and body temperature from connected sensors [45]. A

generic IoT framework can build a smart system, but may not function as effectively as a customised framework for specific industry or application. The smart home concept, commencing different vendors associated with edge computing, diversity of appliances, services, standards and data formats. Therefore, a Cloud-based model has been developed to enable seamless interaction on mixed devices and services from different solution providers [46].

The review shows that most studies have provided useful IoT frameworks, including generic frameworks and customised for fulfilling niche sectors. Most researchers proposed IoT frameworks for a new production line and therefore did not discuss challenges involved in modifications of the existing production lines. Consequently, the main gap has been identified as a lack of R&D for transforming conventional home appliances to smart in established factories with limited resources to change the existing production lines.

2.1. Frameworks

Things are connected more than ever as advance SPSs are emerging over Industry 4.0. Therefore, smart devices generate more data during usage due to multiple connected sensors and actuators. To shape ideas and help to implement smart home appliances, a framework as a tool supports achieving goals by providing a pattern of expandable solution. Due to rapid changes in the Industry 4.0 era, the vertical (e.g. smart appliances toward smart houses, buildings and cities) and horizontal (e.g. smart refrigerator, washing machine, microwave, and voice-enabled smart devices) integration need appropriate IoT framework for specific industry applications such as a smart home system. An IoT framework could develop smart products due to integration between a range of communication protocols, deployment at the Edge, and Cloud services. IoT frameworks are keep changing due to new requirements since Industry 4.0 introduced in 2010. Regardless of specific SPS, every industry may need a customised framework. Fig. 2 shows a conceptual IoT-enabled smart products and systems framework consisting of four parts, 1) Smart Appliance; 2) Wireless Protocol; 3) IoT middleware and 4) Cloud, where smart home appliances are connected to the Cloud by using wireless protocols and an IoT middleware.

This framework is suitable for all home appliances by using smartphones as a gateway to access wireless capabilities, internal memory and process for using Cloud-based resources. As mentioned in the literature, most frameworks have developed for different industries and specific applications. A generic framework does not always fulfil the requirements concerning lead time, cost, complexity, flexibility and expansion, for instance, from smart home appliances to smart home systems. Often, they offer much functionality that is not necessary because it may lead to significant overhead in respect of effort, design, and resources. Making an ordinary home appliance smart requires a structured and expandable solution, and customisation needs to take place in three parts, applications, industries and technologies. This study is limited to home appliances using IoT. Therefore a custom framework is considered to enable shorter lead time, minimum cost and effective vertical and horizontal expansion.

The main objective of this framework is to collect data from a home appliance through connected sensors and actuators using IoT over Cloud. This is, therefore, an IoT-enabled framework, which relies on big data analytics to convert data to information, knowledge and wisdom. However, this framework has driven the bottom layer of DIKW (data, information, knowledge, and wisdom), hierarchical model, with data at its base. This framework is data-oriented, emphasising seamless integration by enabling big data analytics to illustrate how a smart appliance can be provisioned and connected to a smart home system. This framework is data-oriented, focusing on seamless integration and enabling big data analytics to illustrate how a smart appliance can be provisioned and connected to a smart home system. It is a data-oriented framework because it is motivated by efficient usage of IoT to create extra value out of data. This framework can enable capabilities such as

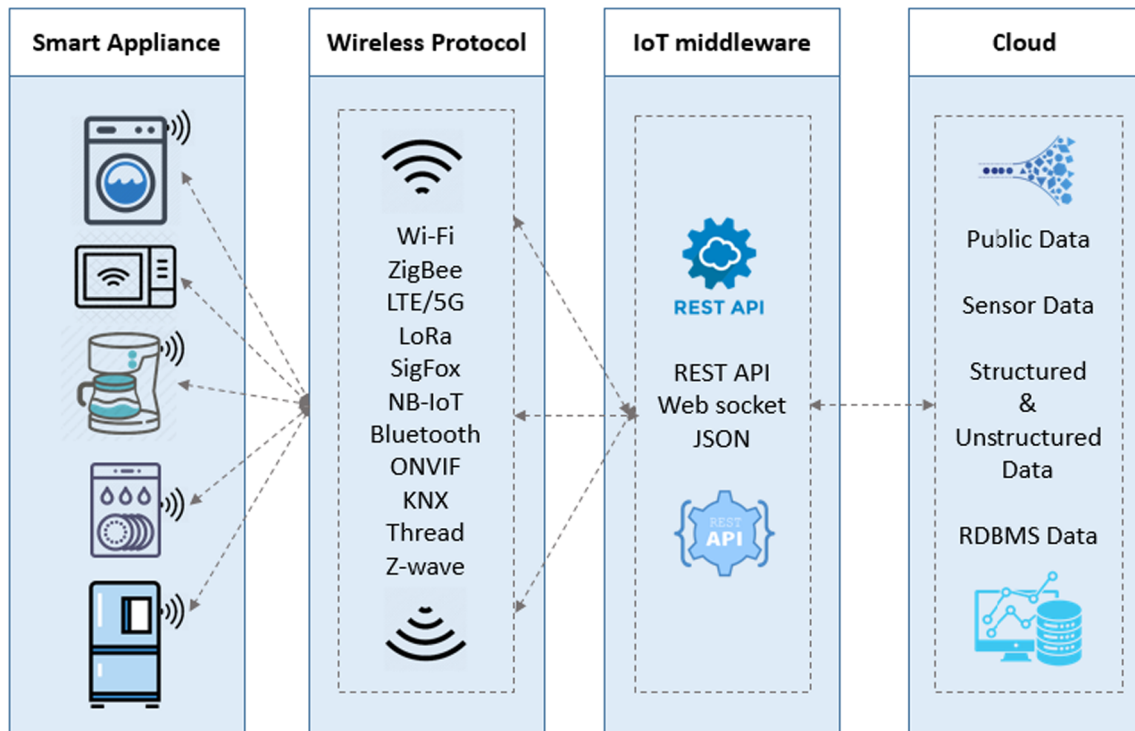

Fig. 2. A conceptual IoT-enabled smart products and systems (SPS) framework.

the mitigating risk of failure in a smart home appliance system similar to knowledge-oriented, decision-oriented, and system-oriented frameworks. However, this framework is in a lower hierarchy level. Therefore, the proposed framework can be a prerequisite for the frameworks mentioned above.

Although existing frameworks can be applied to smart home appliances, this framework offers a simple approach to transfer data at home and meeting greater control over door locks, lights and appliances. This framework may not work well for other applications and industries as modified for connected appliances through IoT middleware for further big data analytics on the Cloud. This framework does not target all industries, instead adopted to devices at home and using an IoT middleware rather than an industrial IoT platform. This framework is not complicated as an IoT-enabled framework for product personalisation, which may need to manage ambiguous situations [47].

This framework is data-oriented, focusing on seamless integration and enabling big data analytics to illustrate how a smart appliance can be provisioned and connected to a smart home system. The demand for diverse SPSs with specific functionalities and applications has encouraged industries to develop IoT platforms. Reference architectures such as Google Reference Architecture, AWS Reference Architecture, and Azure IoT Architecture are mature in providing generic abilities but with different level of integration, supporting protocols, messaging and authentication capabilities. Finally, yet importantly, ease of development is one of the critical factors for IoT framework through providing Software Development Kit (SDKs) and Application Programming Interface (APIs) to expand functionalities. Besides the proposed conceptual framework, IoT solution providers are increasing device interoperability, seamless data sharing, and connectivity to the Cloud along with analytics that offers value-added services. The use of IoT framework in a smart home system is essential due to faster development and continuous value delivery on customer's requirements. Using IoT framework, empowered smart appliance development to keep the integration independent to protocols and technologies used.

2.2. Platforms

A wide range of business sectors, including but not limited to healthcare, energy, transport, aerospace, autonomous vehicles, industrial equipment and smart devices have utilised different IoT platforms. Table 1 lists the most used IoT platforms along with functionalities, supported protocols, service type, and some real-life SPS. The objective of this section is to review and analyse the implication of IoT platforms and find a simple yet suitable IoT platform for rapid SPS development, in particular, transforming conventional appliances to smart. IoT platform selection is a complicated process due to some factors comprising, infrastructure, communication protocols, resource constraints, business model, and smart applications such as smart appliances, smart home, smart cities, and smart grid. Almost all IoT platforms are providing similar functionalities, so the selection becomes more challenging across more than 300 platforms by the end of 2018. Developing sustainable SPS become more feasible in the Industry 4.0 era by using a suitable IoT platform.

Utilising an appropriate IoT platform, edge computing and Cloud-based services such as software as a service (SaaS), platform as a service (PaaS), and infrastructure as a service (IaaS) becomes the core of the next SPS generation. The vertical and horizontal integration has made an enormous number of SPSs with the highest efficiency. IoT platforms and edge computing have enabled developers to bridge the gap between Cloud and physical things. The edge model can simplify complexity through modular architectures and rapid development. Hence, an IoT platform with edge computing, Cloud, and big data can enable the development of SPS, such as fitness trackers, smart medical devices, smart appliances, smart home and smart city systems.

3. Case study

This section reports on a case study to demonstrate how Industry 4.0 technologies, in particular, IoT, Cloud, Edge computing, and big data could transform a conventional refrigerator into a smart product for expediting extra value. This experiment provides an engineering product development from identifying requirements, design, prototype,

Table 1
IoT platforms for smart products and systems.

IoT platform	Functionalities	Supported protocols	Service type	Real-life products & systems	Reference
AWS IoT	Connecting things, secure interactions, data process, and even offline interactions of products, services and systems.	HTTP Web Sockets MQTT	PaaS SaaS IaaS	Messages can be routed to AWS endpoints, e.g. Lambda, Kinesis, S3, Machine Learning, DynamoDB, CloudWatch, and Elasticsearch Service with built-in Kibana integration	www.amazon.com
Azure IoT Suite	Easy integration with ERP /SAP, CRM/Salesforce and Microsoft Dynamics. Remote monitoring, predictive maintenance, connected factory devices.	HTTP AMQP MQTT	PaaS SaaS IaaS	Tetra Pak (keeping food & drink safely), Rockwell Automation (Smarter industrial machines), ABUS (Safeguard development), Kennametal (Innovation in metal science)	azure.microsoft.com
Google Cloud IoT	Utilised Google's backbone and integrated with Google's web processing, analytics, and machine intelligence	MQTT HTTP GCM	PaaS SaaS IaaS	Philips, Spotify, Zully, Scitis, Airbus, GOJEK (logistic & payment), Oden (IoT manufacturing), Motorola, Ocado (Improved customer care and operations with machine learning)	cloud.google.com
IBM Watson IoT	Machine learning, automated data processing, analyse real-time IoT data, IoT app development supporting Raspberry Pi	MQTT	PaaS SaaS IaaS	WellPoint (improve health outcome for 33.5 M members), KONE (Connects 2 million elevators), ISS (Managing 25,000 buildings worldwide), Teradyne (tracking facility utilisation)	www.ibm.com
Kaa IoT Platform	Open Source, hardware integration. Licensed under Apache Software, Horizontally scalable handling millions of devices	HTTP TCP	PaaS	Agriculture, Industrial IoT, Automotive, Smart City, Smart Energy, Smart Retail, Sport & Fitness, Logistics, Telecom, Consumer Electronics, Wearables	kaaproject.org
PTC ThingWorx	Provides flexibility and scalability for building Smart Factory solution and industrial IoT applications	MQTT REST	PaaS SaaS	Elisa (Smart Factory solution that monitoring, manage and alter production process), Vodafone (Smart City that helps manage cost, growing economic prosperity and support sustainability)	ptc.com
ThingSpeak	Open Source IoT analytics platform allows aggregating, visualising and analysing live data streams in the cloud.	ODBC HTTP RESTful MQTT APIs	PaaS	ThingSpeak enables the creation of sensor logging applications, location tracking applications, and a social network of things with status updates	thingspeak.com
WSO2 IoT	WSO2 brings flexibility to mobile projects. It provides manufacturers to develop connected products as well as rich integration and smart analytics capabilities.	MQTT HTTP Web Sockets XMPP	PaaS	Verifone (Customer engagement in a payment terminal project), T-Systems (connected cars product), digital (smart home and smart health products), Pacific Controls (Green City), Two Degrees (SOA/ESB)	wso2.com

and test to commercialisation and operations. The aim of using IoT in a smart home is to optimise electricity usage, offer personalisation, enabling advanced maintenance, and affordable system upgrades with higher customer satisfaction. This case study was dedicated to mass production of ordinary refrigerators in Medellin, Antioquia.

This effort is part of a portfolio, including several IoT-enabled home appliances projects in an established factory with over 70 years of operations. Converting ordinary home appliances to smart ones is highly demanded concerning the minimum impact on current production lines. Although this paper focuses on refrigerators as a typical home appliance, other appliances such as washing machines can become smart through the same approach.

This industrial case study can be extended to all the smart home appliances and the proposed framework can be adopted by other home appliances due to similarities, such as network connections, limited operations, data volume, data structure, response time, and the most crucial feasibility to embed a customised IoT-enabled board inside each home appliance. Finally, yet importantly, utilising a single IoT-middleware and mobile app for individual home appliances. Several user acceptance tests for different appliances have been accomplished, but the ultimate goal is to offer a unique smart home solution for all appliances.

This section presents several aspects of an end-to-end IoT-enabled smart appliance system. The system in Fig. 3 consists of three main divisions: 1) smart product 2) communication protocol and 3) real-time monitoring and control. Firstly, the refrigerator needs to be upgraded to become a digital asset rather than just a physical product. Secondly, proper wireless communication is required for building a CPS. Lastly, an IoT framework with visualisation and Cloud capabilities is essential. The entire section discusses current challenges, PCB design, network connections (Wi-Fi and Bluetooth), edge computing, hardware architecture, firmware architecture, IoT platform, real-time monitoring/dashboard, software including firmware and mobile app development.

3.1. Challenges

An IoT-enabled smart refrigerator can communicate, receive updates and offer new features as it is developed and released. IoT-enabled refrigerator, also known as internet refrigerator, should get

smarter, stay up-to-date, and keep track of customer usage. The most important technical challenge is to utilise Industry 4.0 technologies for transforming conventional home appliances to smart in established production lines. The case company has recognised the high customer demand for smart appliances in the competitive global market as the most critical business challenge. The case company produces a portfolio of home appliances, including but not limited to the refrigerator, washing machine, and microwave. Hence, after careful consideration, the refrigerator was selected for digital transformation across all home appliances that have been manufactured for more than seven decades in the factory. Several technical challenges have been raised during the feasibility study. For instance, lack of access to the critical operations of the refrigerator, in particular compressor. Also, the absence of monitoring and a user-friendly control system were highlighted by authors. The refrigerator has an embedded control system. Therefore, the first vital technical challenge is decoding the signals to and from the conventional refrigerator's control board. The second constraint is to design a PCB for IoT board to be installed in the best possible location without any change in the product design. Besides, the highest access to Wi-Fi signal with standard temperature was compulsory for the IoT board. The next problem was enabling Internet access via Wi-Fi at home because an ordinary refrigerator does not have a keyboard and display for finding an internet access point. The fourth challenge was to develop a real-time monitoring and notification system. Finally, yet importantly, it was required to keep the data available for further investigation such as personalisation, energy efficiency optimisation, compressor performance improvement, and predictive maintenance.

3.2. Design

Designing a board for a conventional appliance requires seamless integration between sensors, actuators and electrical systems. This refrigerator was manufactured to use a central control board. Therefore, a new IoT board has been designed for working between the refrigerator, user and potentially the factory. The current system board has been kept without any change to save the cost at the lowest possible. The new PCB (printed circuit board) for IoT has to be placed into a small space while preserving reliability and product budget. Flexible PCB's have emerged as the best strategy for IoT-enabled R&D projects. With

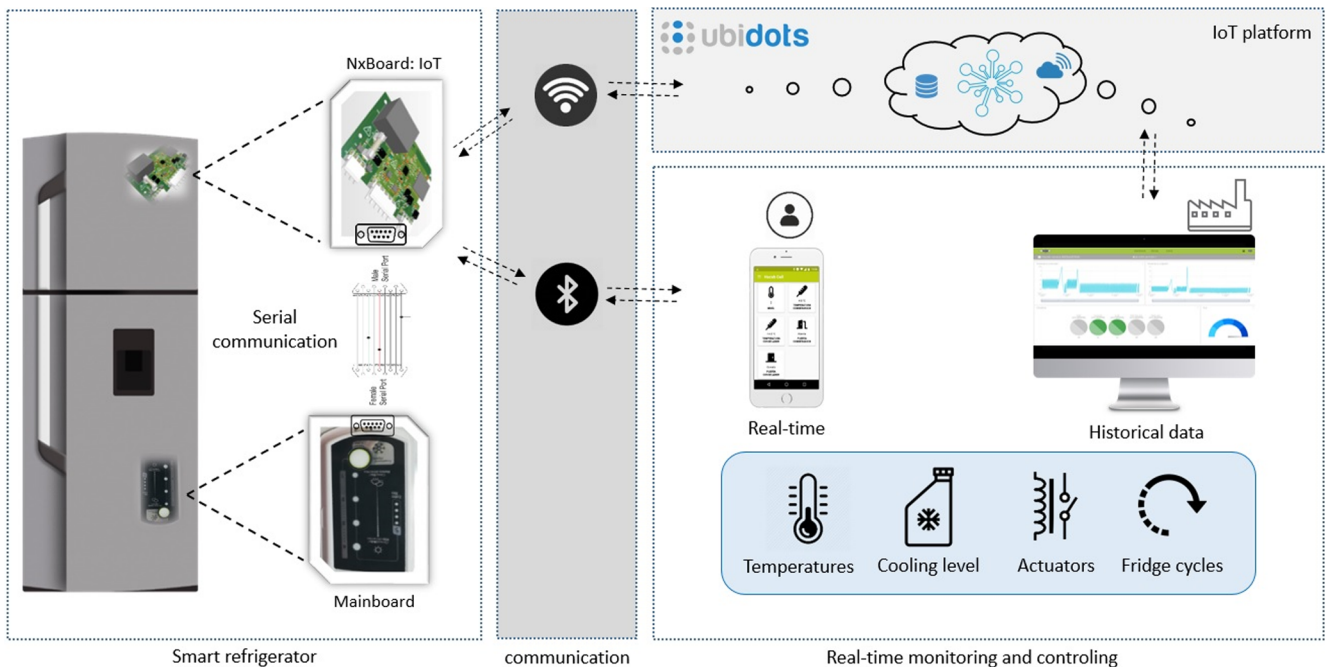

Fig. 3. End-to-end IoT-enabled smart home appliance system.

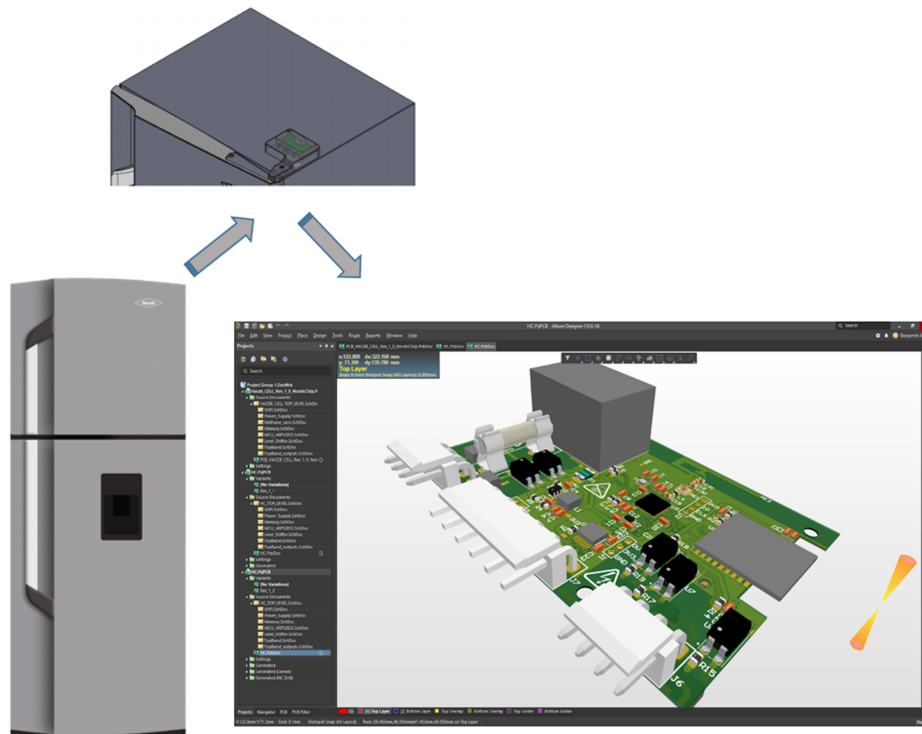

Fig. 4. The third version of the IoT board with high signal strength position and easy to assemble.

support for flexible PCB design, comprehensive testing tools, and an in-built interface, Altium as a reliable, trustworthy software has been used. The component placement was optimised for space and performance based on the mechanical constraints on the top right side of the refrigerator's door. The PCB shape was modified to accommodate the board in the place. After the validation of the correct functionalities, several improvements have been considered including 1) better connectors for AC signals 2) DC and AC decoupling 3) Wireless (Wi-Fi and Bluetooth) antenna position. Fig. 4 shows an improved PCB design for IoT-enabled refrigerator. This design process has placed some essential criteria to meet requirements with efficiency.

First, the factory operator should be able to assemble the IoT with limited effort and time. Second, the IoT board should be located in a place with the highest access to the Wi-Fi access point at home and Bluetooth on a smartphone and gain the highest cell signal strength. The most powerful cell phones can transmit a signal of 3 W. The low power limits the range of a Bluetooth device to about 10 m and cutting the chances of interference between other smart devices at home. The final design was delivered for communication with the mainboard and IoT middleware at the same time.

Sections 3.3–3.9 represent how this study used suitable network connections such as Wi-Fi for this experiment. This study is restricted to using off-the-shelf boards because the factory was built over 70 years ago and the objective was to save time, cost, and effort for using the current production line aimed at building smart home appliances. Instead, this study introduced an IoT-enabled system and placed a PCB board with embedded network capability in ordinary home appliances.

3.3. Network connection

One of the most crucial considerations for an IoT-enabled system is to establish a secure, compatible, reliable and expandable network connection. Network connection of IoT is increasingly becoming an essential feature of R&D projects for collecting data from things. IoT-enabled systems also need to be kept extremely secure due to the potential impact if they were hacked. Some smart products are not

engineered to auto-update and are often left unprotected due to out-of-date firmware or software. In this study, both hardware and software along with network connection and IoT platform were developed for a secure solution. IoT home appliances need the Internet and LAN connection to expand a smart home, utilise 3rd part service providers, and Cloud capabilities. The connection to the Internet allows residents to communicate with the smart home, access real-time information and perform tasks remotely. This experiment used Wi-Fi and Bluetooth network connections.

3.3.1. Wi-Fi

The goal of transforming appliances to intelligent and connected things is to make a smart home. Therefore, Wi-Fi has been chosen for data transmission between the IoT board on the refrigerator and the Cloud by using Ubidots as an IoT platform.

Nowadays, for connecting homes to the Internet, Wi-Fi is the most cost-effective wireless connection at home and DSL is the most used network technology for connecting to an ISP. Fig. 5 shows sharing a wireless Internet connection, a modem plugs to the DSL cable and enables Wi-Fi connection between the smart refrigerator, user, and Ubidots, an IoT platform. In this study, a Wi-Fi module was selected and embedded to the IoT board. An ESP8266 module was used as a microcontroller for data processing and communication.

3.3.2. Bluetooth

One of the main network challenges is a secure connection to the Internet via Wi-Fi at home. In the previous section, using ESP8266 as a low-cost Wi-Fi microchip with full TCP/IP stack and microcontroller capability was discussed. However, the issue remained because an ordinary refrigerator does not have a keyboard and display for searching and selecting a Wi-Fi access point and enabling a secure connection by using a password. Two solutions were proposed to address this challenge: 1) Hardware solution by adding a small keypad and TFT LCD screen and 2) Software method by integration between refrigerators' physical control system, the IoT board, and a mobile app. The second option was selected due to advantages such as easy to changes,

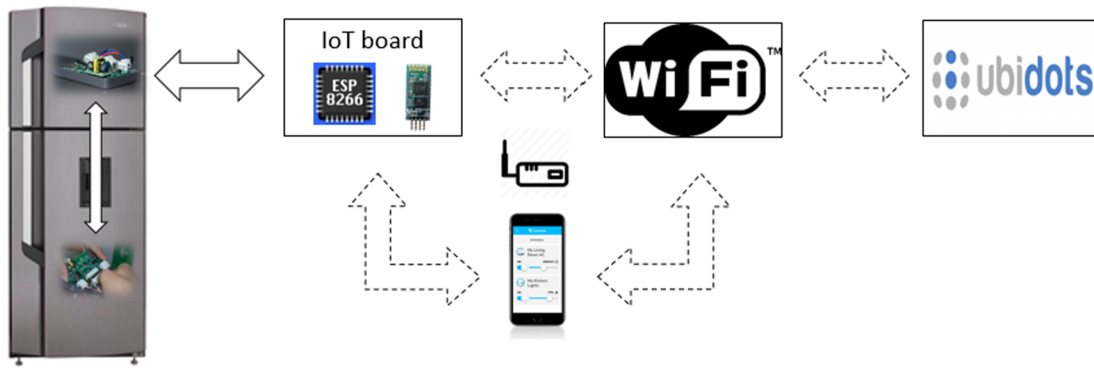

Fig. 5. Wireless network connection and IoT platform enabled smart refrigerator.

upgrade, user-friendly, and cost-effective in mass production. The refrigerator only needs one button as an interactive interface for making a Wi-Fi connection. Therefore, the user needs to scan available networks, send credentials to the Wi-Fi module, and establish a secure connection. That is why a mobile app was developed to provide a secure connection through Bluetooth to IoT board. Moreover, as the used microcontroller has an embedded Bluetooth module, we took advantage of this convenient communication network.

3.4. Edge computing

Edge provides data closer to the Cloud storage using Ubidots IoT platform where real-time monitoring and dashboard required. This microcontroller pushes data collected from sensors and current board and enables meaningful data closer to the user. This part extends data processing, big data analytics, prediction and maintenance to the Cloud database on Ubidots.

This study follows an agile design methodology to meet IoT-enabled smart appliance at a cost and time defined together with the factory management. Suitable technologies were evaluated after the scope was defined, and functionalities were specified. The Pugh Matrix as a decision-making tool was used for concept generation and selection. Therefore, the component that best matches the criteria was selected as Table 2 shows a list of microcontrollers that were reviewed before we started the design process. On this matrix when the “=” symbol indicates a reference which the other alternatives compared with, and “0”, “1”, and “-1” indicate if the compared element is equal, better or worse than the reference component. The “relevance” column provides weight for each element according to the importance given to that item. The score for each item was multiplied by its weight, and the results as the total points were provided. Therefore, the most appropriate microcontroller for transforming a refrigerator to a smart one was nRF82832 manufactured by Nordic Semiconductor. The nRF52832 is the mid-range member of the nRF52 Series SoC family. This microcontroller meets the challenges of an IoT broad range of smart home applications that are fully multiprotocol capable with full protocol concurrency. It supports Bluetooth 5, Bluetooth mesh, ANT and 2.4 GHz

Table 2
Pugh matrix for microcontroller evaluation.

Criteria	CC2640R2F Reference	DA14585	BLUENRG-248	NRF52810	CY8C4128LQI-BL543	NRF52832	Relevance
Cost	=	1	1	1	0	0	13
Memory	=	-1	0	-1	0	1	8
RTOS	=	-1	-1	0	0	0	5
BT topology	=	1	0	0	0	1	8
Architecture	=	-1	-1	1	-1	1	5
Development time	=	-1	-1	1	-1	1	13
Total	0	-2	-2	2	-2	4	N/A
Weighted	0	-10	-10	23	-18	34	N/A

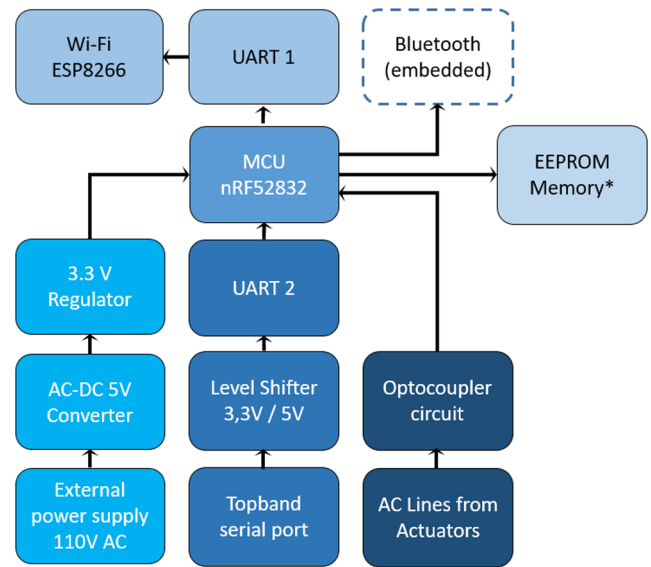

Fig. 6. Hardware architecture for IoT enabled smart home appliance.

proprietary stacks.

3.5. Hardware architecture

In this experiment, hardware architecture refers to the identification of IoT boards’ components and their interrelationships. As Fig. 6 shows this hardware design model, demonstrates how core components fit into this IoT board and provide a wireless connection to Ubidots, IoT platform by using ESP8266 as a low-cost Wi-Fi microchip compatible with full TCP/IP stack for further development.

The MCU: nRF52832 as a suitable microcontroller for IoT-enabled smart home appliance allows accomplishing the different required features as follows:

- Receive information from the main board of the refrigerator: the main board of the refrigerator (called Topband) receives information from the sensors and controls all the actuators on the fridge. It sends information through a serial protocol that we receive and process on our board (through the UART).
- Read the states of the different actuators of the refrigerator: it has 5 actuators (heater, compressor, air fan, fresh food door and freezer door). Through General Purpose Input/Output (GPIO) pins, the IoT board knows when they are turned on or off.
- Send real-time information through Bluetooth: the embedded Bluetooth module that the nRF52832 has, allows us to send the information that our IoT board receives from the Topband to the mobile application developed.
- Send information periodically to Ubidots: to keep records of the data from the refrigerator, the IoT board sends the data periodically through Wi-Fi to the Database called Ubidots. The microcontroller switches the UART to communicate to the ESP8266, send the data and then switch back to continue receiving serial data from the Topband.

3.6. Firmware architecture

The firmware provides a standardised operating environment and a low-level control for the IoT hardware board. As Fig. 7 shows, the four layers consist of hardware abstraction layer (HAL) firmware, drivers (UART, Timers, GPIO), Libraries, and application on top of the architecture.

This study took advantage of the Software Development Kit (SDK), which developed by Nordic Semiconductor. Some of the modules used for this R&D project are on the Hardware Abstraction Layer (HAL) in Fig. 5, such as UART for serial communication, TIME to control some periodic tasks on the application, and GPIOTE to manage the Input/output pins. Above the HAL is the Drivers layer: where functions have to implement for the peripherals needed. Then come to the Libraries layer, where functions for specific modules or sensors take place, for instance, functions to drive the BLE or the ESP8266. Finally, the main program developed in the application layer. Functions from the Libraries layer called to accomplish all the functionalities required.

3.7. IoT platform

An IoT platform is a multi-layer technology that enables

straightforward provisioning, management, and automation of connected things such as sensors, actuators, and connected devices. In this experiment, a secure, managed platform has used to provide visibility and control over connected refrigerator with easy build to scale and data autonomy, all in one solution. Not only this IoT platform connects things but also have the ability to create rules (data ingestion, data processing, 3rd-party integration, real-time notification) that react to what is happening in a connected product. As Fig. 8 shows, the IoT platform implemented for this R&D consists of three stages: (1) data capture, (2) management and (3) user visualisation. An embedded board has designed and placed inside the refrigerator for data collection from different sensors. So, a range of different data type including Boolean, integer, character, and stream presented real-time on the user's smart device and stored to the Cloud database via Ubidots, an IoT platform. The information can be visualised in real-time using live dashboards on the mobile application, downloading archive data and create event alerts.

3.8. The real-time monitoring and notification

Smart IoT monitoring from the edge to the Cloud provide unique user experiences by seeing real-time information and advanced analytics result on a dashboard. The smart refrigerator has enabled to leverage AI-driven big data analytics for automated fault detection, root cause analysis and personalisation. Providing visibility into a smart home across all IoT-enabled appliances, analyse user data in real-time to measure satisfaction, detect struggles, predict and offer personalised options. Real-time monitoring capabilities have supported by Industry 4.0 technologies, including Cloud and IoT. Ubidots is an IoT development platform that allows users to visualise and analyse the data received from connected devices. Ubidots has different tools to extract valuable information from the collected data. Fig. 9 shows some visualisation tools such as variable tables, line, histograms, and pies charts.

The smart refrigerator dashboard has line charts useful to visualise both digital and analogue time-based variables. Fig. 10 visualised fresh food and freezer temperatures by using line charts and the instant state of the compressor, defrost heater, and air fan. Also, the cooling level visualised by using a gauge indicator.

Fig. 11 shows a time-based line chart to analyse the actuators' status in the refrigerator, such as a compressor, defrost heater, and air fan. To determine the system performance, a comparison of this information

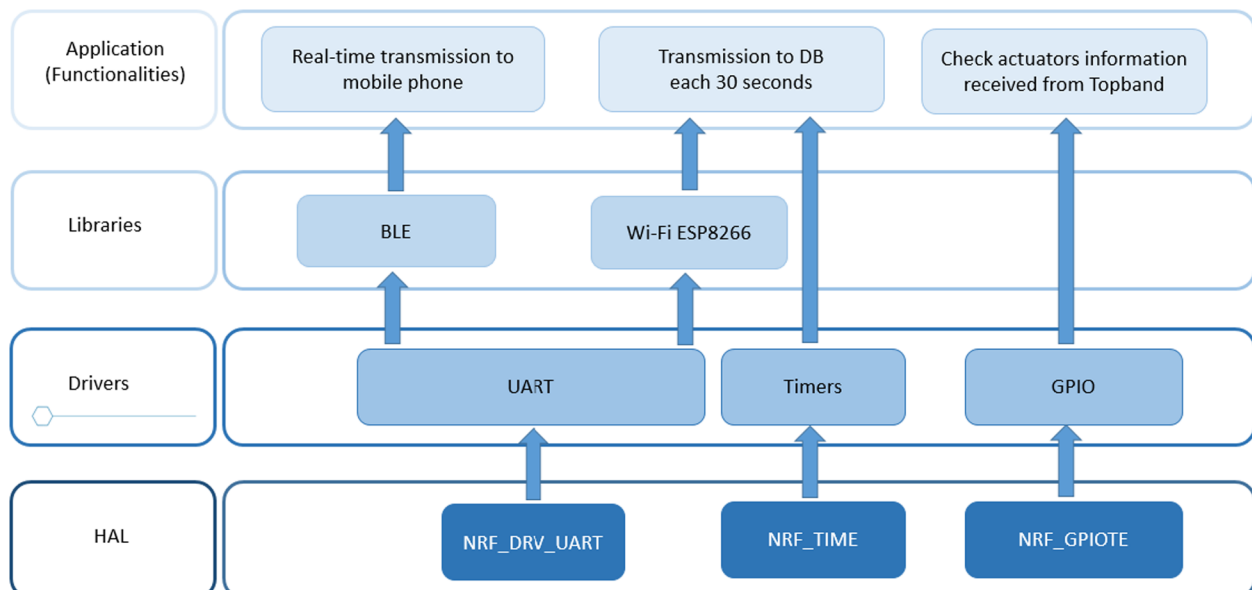

Fig. 7. Firmware architecture for IoT enabled smart home appliance.

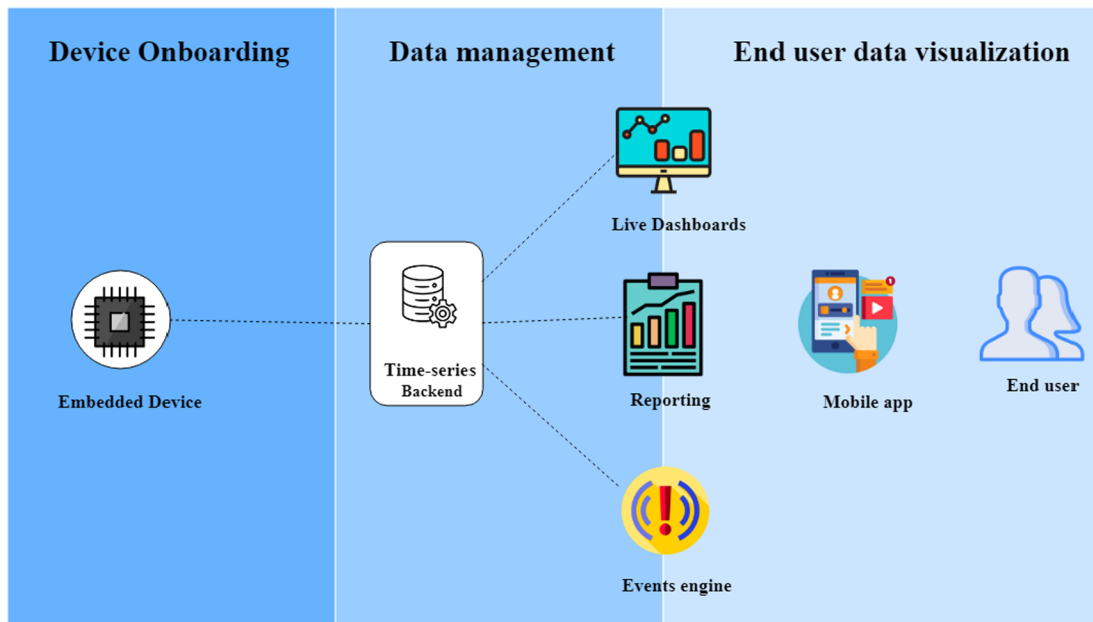

Fig. 8. An IoT platform architecture enabled smart home appliance.

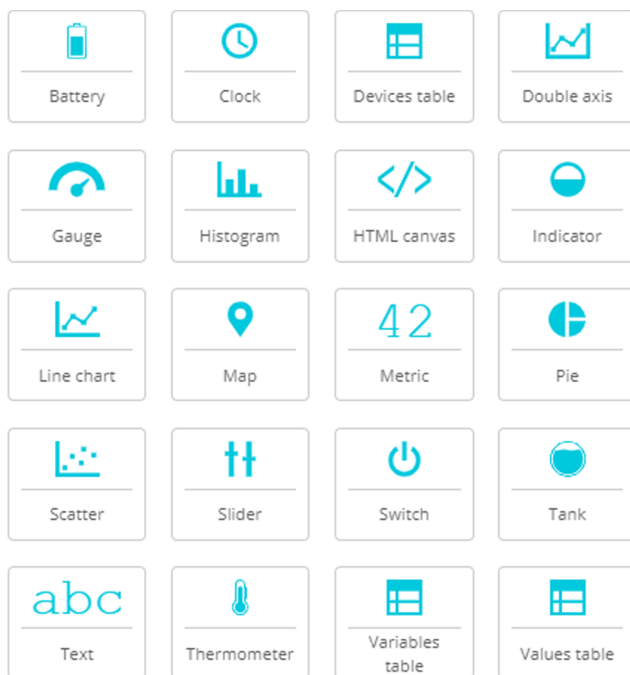

Fig. 9. IoT-enabled analysis and visualisation tools.

with the measured temperatures and other variables is feasible. So, monitored variables as follows:

- Refrigeration level (RL): RL has a range from 1 to 5 according to what the user selects. RL controls at which temperatures actuators including compressor, air fan and the heater turned ON/OFF.
- Compressor Temperature (CT): This is a fixed temperature and depends on the refrigeration level. For example, on level one, the compressor turns ON when the fridge reaches $-4.5\text{ }^{\circ}\text{C}$ and turns OFF when it reaches $-16.5\text{ }^{\circ}\text{C}$.
- Actuators State (A.S): This indicator shows whether the compressor, air fan, defrost heater and any door (fresh food door or freezer door) are ON/OFF.
- Fresh food temperature (F2T) shows the current temperature of the

lower compartment.

- Freezer temperature (FT) shows the current temperature of the upper compartment.
- Compressor turned ON – time (CTT): Shows time while the compressor is ON.

Ubidots, the IoT platform allows a user to configure different events notification by email, call or text message. So, alerts have configured to send a notification when a variable is out of range or has invalid state, e.g., an open door for a long time or a high temperature into the fridge.

This IoT platform provided data collection, store data on Cloud, control appliance, display information, send a notification, run test, update firmware, and deploy device updates seamlessly. This monitoring and notification capabilities combines scalability, fault-tolerance, prediction and maintenance using AI based on big data on the Cloud. Provision, monitor and control IoT-enabled home appliance entities in a secure way between the connected refrigerator, the user or any other smart devices. This monitoring system has integration capability to other smart devices at the forefront of a smart home.

3.9. Software development

One of the most critical aspects of IoT relates to the data enriched by software elements. Devices are getting smarter, interacting with each other and cutting out human gradually, which result in higher customer satisfaction and greater productivity. Once smart appliances enabled smart home, software plays a more critical role as a value-added service (VAS) to develop Internet-connected applications. Software development gives IoT the power to achieve ultimate flexibility, scalability, and velocity. The next two parts have discussed firmware development in addition to mobile development. However, dealing with large-scale data generated by IoT-enabled appliance require analytics using big data.

3.9.1. Firmware development

This experiment defines versions of the firmware according to the different functionalities that the board has to accomplish. Tools such as SourceTree and Bitbucket have used so that team members could develop features at the same time. The C language has used for the software and firmware development. The version 0.1.0 of the firmware included BLE communication. Based on Agile product development, a

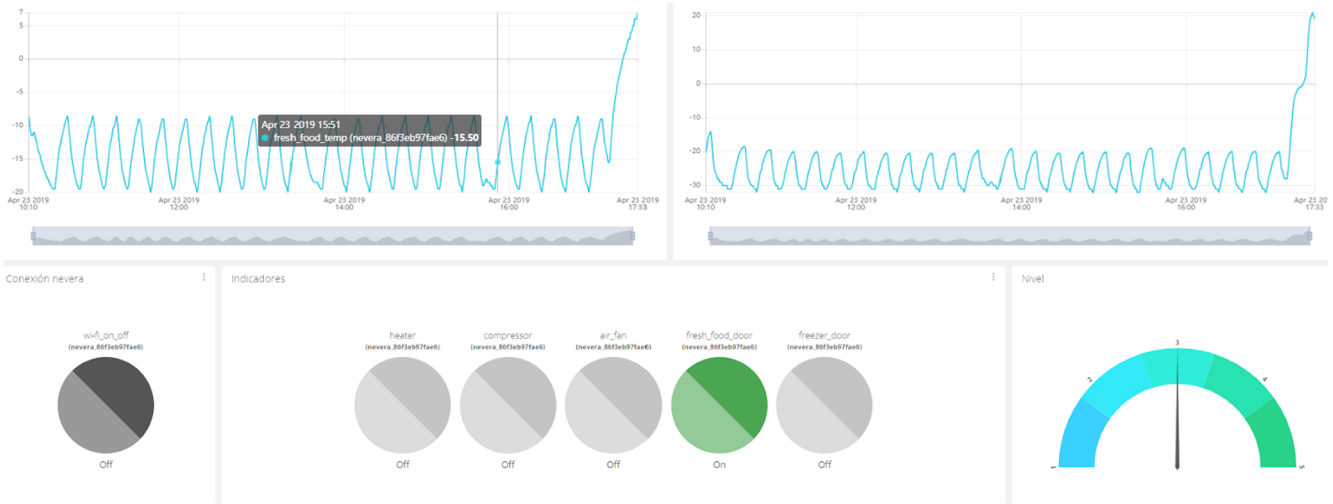

Fig. 10. Fresh food and freezer temperatures with state of actuators including compressor, air fan, heater, fresh food and freezer doors.

comprehensive test required before release any feature. This first feature tested with the app nRF Toolbox which developed by Nordic Semiconductor. Then the version 0.2.0 included communication with the Topband and translation of the frames received. Version 0.3.0 included AC detection that is reading with the GPIO pins if the actuators were On/Off. Version 1.0.0 included the integration of the Wi-Fi module for every 30 s, transmission to Ubidots and improvements on the application (defining a state machine to take more control over the code).

3.9.2. Mobile app development

The objective of this study is to keep the current production line unchanged by using embedded IoT-enabled board capabilities. Due to the situation, a secure connection (login credential, user ID and password) to the Wi-Fi was a severe challenge because there was no keypad or touchscreen on the refrigerator. A combination of existing buttons inside the refrigerator, the new IoT-enabled board, and the pseudocode shown in Fig. 12 made the process possible. Using a mobile device to replace a microcontroller and a mobile app as a user interface is part of the solution for interaction between a user, refrigerator, and Wi-Fi access point. This code allows a user to find available Wi-Fi networks, choose one, enter a password and send those credentials to the IoT-enabled board for a secure Internet connection.

At the same time that the incremental firmware versions developed, a mobile app in Kotlin developed. Kotlin is a cross-platform programming language that designed to interoperate fully with Java, and the

JVM version. The objective of the mobile app was to show in real-time the data from the refrigerator. Besides, this mobile app provides a Wi-Fi connection to the refrigerator. By interaction between a user and refrigerator and Wi-Fi access point. This app allows a user to scan the available Wi-Fi networks, choose one, enter a password and send those credentials to the IoT board for a secure Internet connection. After the first version of the code had released and the board with different functionalities presented to the stakeholders, a pilot with ten refrigerators had considered. During the pilot, some changes suggested improving the product through Iterative and Incremental development process. For instance, door-related events (formerly, the board only transmitted events every 30 s to Ubidots) should be communicated immediately as a real-time event. Moreover, reconnection to Wi-Fi periodically (if the Wi-Fi turned OFF, the board should connect when the Wi-Fi is ON again). Those changes have implemented on the application and released as the version 1.1.0.

The Pseudocode in Fig. 12 shows the interruption handler in which credentials for Wi-Fi (SSID and password), processed through Bluetooth. Once the IoT board has the credentials, it is enough to call the `esp8266_connect` (`esp8266_connect (&esp_obj. uart_instance, SSID, password)`) function from the application which defined on the `esp8266` library.

The rest of the application as follows:

- **IDLE:** In this state, the machine is continuously looking for conditions to meet to execute any functionality from the other states.

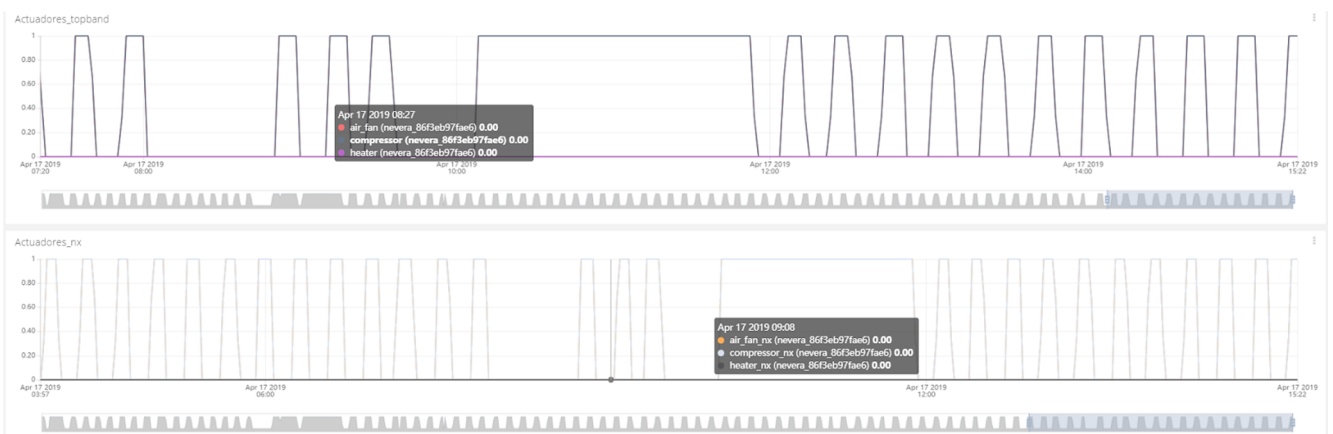

Fig. 11. Comparison between the behaviours of the compressor, defrost heater, and air fan.

```

if "data through Bluetooth has been received"
    clean variables SSID and password
    copy the revised data on a buffer
if "received data includes Wi-Fi credentials"
    split SSID and password
    While "split SSID and password are not NULL"
        save SSID and password on position 0 and 1 in a buffer
        save position 0 of the buffer on SSID variable
        save position 1 of the buffer on password variable
        set the flag for wifi_credentials_configuration
    else
        clear wifi_credentials_configuration
    end if
    clear the buffer
function microcontroller_connect (UART instance, SSID, password)
if "UART instance is initialised"
    set up UART
    clean the buffer
    send SSID to the microcontroller
    send the password to the microcontroller
    return response from the microcontroller
else
    uninitialise the UART
end if
return TRUE

```

Fig. 12. The Pseudocode for secure smart appliance connection.

- **INIT:** Is the state that executes every time the board starts. Here all the configuration of the pins of the microcontroller is done and the initialisation of the modules such as the ESP8266 so that the IoT board gets ready for its operation.
- **RX_TOPBAND:** If there is data available through the UART port (received from Topband), then the board processes all the received information.
- **DATA_MANAGEMENT:** According to the communication protocol, the microcontroller reads each value and saves them on a buffer to prepare the information to the transmission to Ubidots.
- **BLE_ON:** If the user pressed the button in the Topband reaching level 3 of refrigeration, it means that the user wants to activate the advertising of Bluetooth to connect with the refrigerator. In this state, the advertising started.
- **SEND_BLE:** If there is a successful connection through Bluetooth in this state, the board sends real-time information about the refrigerator each second.
- **SEND_WIFI:** Information sent through Wi-Fi according to the period setting with a macro (a global variable that could be easily modified) defined on top of the code.
- **RETRY_WIFI_CONNECTION:** If the Wi-Fi connection lost for any reason, this state will check and try to reconnect periodically.

This mobile app visualises useful information by using the real-time and historical record of the smart refrigerator through IoT platform. The developed mobile application allows a communication channel with a smart refrigerator through Bluetooth (which allows a connection range of 10 m approximately with a line of sight). This mobile app provides tutorial, monitoring, notification, access to call centre, diagnostic, and personalisation capabilities.

3.10. Validation

This study took engineering validation due to the nature of

challenging IoT-enabled solutions. Therefore, every component such as a sensor, gateway, user interface, and their inter-connectivity has been tested under multistage validation contains the following components:

1. Smart home mobile app: Different monitoring and control functionalities, such as setting the fridge temperature on smart home app.
2. IoT middleware: The smart home app sends the commands, such as a temperature value through Rest APIs using the backend process.
3. IoT-enabled board: IoT middleware delivers the different functionalities, such as "change temperature" commands to IoT-enabled board installed inside the fridge.
4. Smart fridge: The IoT-enabled board sends the desired temperature on the fridge with a notification on the smart home mobile app once the desired temperature is achieved.

For end-to-end testing, the multi-stage validation has been considered because the verification at each component level is required to ensure the system functionality.

1. The validation requires the smart home app to check the mobile app functionality. Correlating with the set temperature example, the validation, in this case, would be whether the temperature of the fridge is changed to the desired level or not.
2. The validation requires the user to access the network using the IoT middleware APIs. It is mandatory to ensure that the functional requirements meet at the APIs. Moreover, validate logs to make sure that the changes made by the smart home app are sent to the IoT-enabled board through the middleware. Validation ensures that the APIs are working as expected, and the changes are made in the log file.
3. The verification is needed at the IoT middleware where requirements such as "temperature change" command using JSON for communication. The validation is done if the correct message is received by the IoT-enabled board and forwarded to the fridge via Bluetooth and Wi-Fi communication protocol. The validation is to ensure that the temperature change is made for fridge over Bluetooth and Wi-Fi communication protocols for the temperature change example.

At last, the validation is required at the embedded IoT-enabled board to ensure that the action received from the IoT middleware reflects on the IoT-enabled board. The validation is to make sure that the temperature gets set to the desired level on the fridge for the temperature change example. The fridge sends the "Desired temperature is achieved" notification to the smart home app via IoT-enabled board and IoT middleware. The smart home mobile app, IoT-enabled board, and IoT middleware are validated once the mobile notification is generated from the fridge.

Besides the end-to-end test, this study made a detailed validation for the IoT-enabled board. The first validation step is to focus on hardware. Fig. 13 shows the points that have been measured not only during simulation but also during operations. Once the IoT-enabled board has been electrically tested, the next step is to test functionalities such as:

1. Program the microcontroller (MCU) successfully.
2. The MCU enables Bluetooth when required.
3. A mobile phone pairs successfully with the IoT-enabled board through Bluetooth by using the developed smart home mobile app.
4. The smart home mobile app successfully reports the real-time state of the fridge, for example, the right temperature of the freezer.
5. The smart home app sends credentials of the Wi-Fi network to the IoT-enabled board, and the Wi-Fi module connects to the network.
6. Once the Wi-Fi module is connected, it sends the data to the IoT middleware.

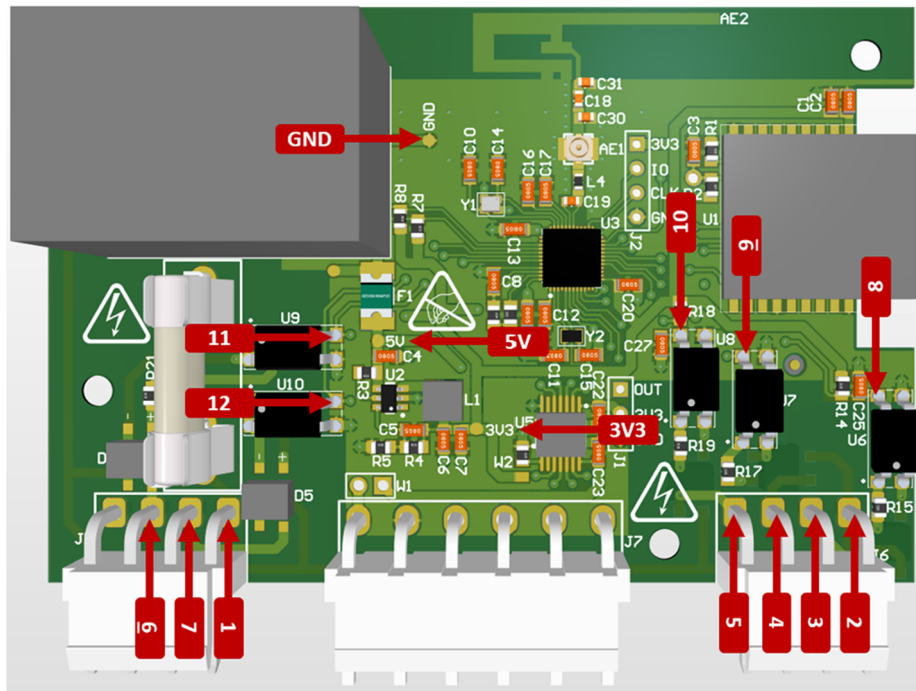

Fig. 13. Points where the IoT-enabled board should be tested.

Finally, when the system is posting data regularly on Ubidots, IoT middleware, the data should be checked. For example, measuring with Fluke, a calibrated and trusted instrument to make sure the temperature that the sensor in the fridge is sending to Ubidots is right. When all the variables are checked, the fridge is passed, and the solution is validated.

4. Challenges and suggestions

The main contribution of this study is making smart home appliances by using the existing production line of conventional home appliances. The future perspective of this study is a seamless integration of different smart home appliances to a smart home system. This proposed framework can be applied to conventional appliances with enough space for adding a customised IoT-enabled board.

Even though established factories have the potential to harvest value by producing affordable products with a commitment to society and the workforce, both customers' demand and market competition are driving the next generation of products. Therefore, the main challenge is how to address requirements by considering the minimum impact on established production lines. This industrial case study covers the challenges involved in making ordinary home appliances as smart as possible. The first and obvious challenge is the product's look and feel because the objective was to avoid any physical changes in manufactured home appliances in the factory. Almost all smart refrigerators in the market have a mounted interface, such as a touch screen on the front door. However, due to the situation in this long-standing factory, any physical changes such as adding a new part cause several other costly and time-consuming changes, for instance, adding keypad or any touchscreen to ordinary refrigerators in the current production line considered as an obvious limitation. Instead, design and development of IoT capabilities by utilising current functionalities led R &D for innovation toward software-defined manufacturing [48–50]. Due to the limited circumstances, a secure connection (login credential, user ID and password) to the Wi-Fi was a severe challenge because there was no keypad or touchscreen on the refrigerator. Therefore, a combination of existing buttons inside the refrigerator, the new board, and a mobile app made this happen successfully. Using a mobile, instead of a microcontroller, and a mobile app, as a user interface, is part of the

solution for interaction between a user, refrigerator, and Wi-Fi access point. Fig. 12 suggests pseudocode (software-defined capability) which allows a user to find available Wi-Fi networks, choose one, enter a password and send the credentials to the IoT board for a secure Internet connection.

Ordinary home products are widely used for routine housekeeping tasks, such as cooking, washing, or food preservation by almost everyone in residential areas. While manufacturing smart product is a trend, there is a considerable demand for transforming ordinary products to smart with minimum effort. However, some constraints, including but not limited to adaptive design, the signal encoding of the mainboard, enabling secure connection, seamless integration, data storage, and lack of embedded keypad and display panel cause challenges.

Unlike computers, IoT-enabled home appliances need limited memory capacity and process. This study has addressed multiple challenges and provided access to further computing process and storage by using the three leading technologies, including edge computing, IoT platform, and Cloud. Many home appliances can bring several functionalities by a secure connection through different network protocols, such as Wi-Fi, ZigBee, 5G, and Bluetooth. An IoT middleware could integrate the refrigerator's sensors and actuators for making smart refrigerator part of a smart home portfolio. This study has used Ubidots as an IoT middleware to bring refrigerator online and provide network connectivity, integration, scalability, cross-platform deployment, real-time dashboard and notification to meet a smart home solution. This study has changed a conventional refrigerator as a typical home appliance, a smart one and demonstrated pragmatic solutions without changing the conventional production line. The factory has minimised the need to shut down the production line resulting in substantial cost savings and tremendous opportunity to transform the entire portfolio to a smart home system.

5. Conclusion

This study shows how a conventional refrigerator can be changed to an IoT-enabled smart refrigerator without changing the longstanding production lines. The proposed framework makes the digital

transformation a feasible and affordable solution to smart home appliances within an adequate lead-time. However, this study is limited to a single vendor home appliance portfolio. While Individual smart home appliances can connect through a single mobile app as a convenient smart home solution, integration to other smart home appliances providers is out the scope of this industry-based research and development.

Declaration of Competing Interest

The authors declare that they have no known competing financial interests or personal relationships that could have appeared to influence the work reported in this paper.

Acknowledgements

The authors would like to thank the Prime Minister's Scholarship for Latin America (PMSLA), the Laboratory for Industry 4.0 Smart Manufacturing Systems (LISMS) and NetuxLAB in Medellin, Antioquia.

References

- [1] United Nations Department of Global Communications, 2019, Sustainable Development Goals: Guidelines for the Use of the SDG Logo, Including the Colour Wheel, and 17 Icons, (January 2018), p. 75.
- [2] A.J.C. Trappey, C.V. Trappey, U. Hareesh Govindarajan, A.C. Chuang, J.J. Sun, A Review of essential standards and patent landscapes for the internet of things: a key enabler for industry 4.0, *Adv. Eng. Informatics* 33 (2017) 208–229.
- [3] N. Verba, K.M. Chao, A. James, D. Goldsmith, X. Fei, S.D. Stan, Platform as a service gateway for the fog of things, *Adv. Eng. Informatics* 33 (2017) 243–257.
- [4] S. Singaravel, J. Suykens, P. Geyer, Deep-learning neural-network architectures and methods: using component-based models in building-design energy prediction, *Adv. Eng. Informatics* 38 (November 2017) (2018) 81–90.
- [5] A.J.C. Trappey, F. Elgh, T. Hartmann, A. James, J. Stjepandic, C.V. Trappey, N. Wognum, Advanced design, analysis, and implementation of pervasive and smart collaborative systems enabled with knowledge modelling and big data analytics, *Adv. Eng. Informatics* 33 (2017) 206–207.
- [6] P. Zheng, C.H. Chen, S. Shang, Towards an automatic engineering change management in smart product-service systems – a DSM-based learning approach, *Adv. Eng. Informatics* 39 (November 2018) (2019) 203–213.
- [7] S. Aheleroff, R. Philip, R.Y. Zhong, X. Xu, The degree of mass personalisation under industry 4.0, *Procedia CIRP* 81 (2019) 1394–1399.
- [8] Zhong RY, Xu X, Aheleroff S. Smart manufacturing systems for industry 4.0: a conceptual framework. *Proceedings of International Conference on Computers and Industrial Engineering, CIE*; 2017. p. 10–31.
- [9] C. Yang, S. Lan, W. Shen, G.Q.G.Q. Huang, X. Wang, T. Lin, Towards product customization and personalization in IoT-enabled cloud manufacturing, *Cluster Comput.* 20 (2) (2017) 1717–1730.
- [10] Gorecky D, Schmitt M, Loskyll M, Zühlke D. Human-machine-interaction in the industry 4.0 Era. In: *Proceedings – 2014 12th IEEE International Conference on Industrial Informatics, INDIN*; 2014, pp. 289–294.
- [11] R.Y. Zhong, L. Wang, X. Xu, An IoT-enabled real-time machine status monitoring approach for cloud manufacturing, Elsevier B.V., 2017.
- [12] S.K. Datta, Vehicles as connected resources, *Ieee Veh. Technol. Mag.* (June), 2017, p. 26–35.
- [13] Z. Jiang, Z. Wang, J. Hu, T. Song, Z. Cao, Research on smart household appliance system based on NB-IoT and cloud platform, 2018 IEEE 4th Int Conf. Comput. Commun. (2019) 875–879.
- [14] A. Parsa, T.A. Najafabadi, F.R. Salmasi, Implementation of smart optimal and automatic control of electrical home appliances (IoT), *IEEE Proc. 2017 Smart Grid Conf. SGC 2017*, 2018-Janua, 2018, pp. 1–6.
- [15] P. Mtshali, F. Khubisa, A smart home appliance control system for physically disabled people, 2019 Conf Inf. Commun. Technol. Soc. ICTAS (2019) 1–5.
- [16] S. Aheleroff, R. Philip, R. Zhong Y., X. Xu, The Degree of Mass Personalisation under Industry 4.0, 52nd CIRP Conference on Manufacturing Systems (CMS), 2019, <https://doi.org/10.1016/j.procir.2019.04.050>.
- [17] A. Valencia, R. Mugge, J.P.L. Schoormans, H.N.J. Schifferstein, The design of smart product-service systems (PSSs): an exploration of design characteristics, *Int. J. Des.*, 2015.
- [18] M.J. Obitko Václav, Big Data Semantics in Industry 4.0 Marek, *Lect. Notes Comput. Sci. (including Subser. Lect. Notes Artif. Intell. Lect. Notes Bioinformatics)*, 2015.
- [19] Chen, Chiang, Storey, Chen, H., Chiang, R. H. L., Storey, V. C., 2018, Business intelligence and analytics: from big data to big impact. *MIS Q.*, 36(4), 1165.
- [20] L.L. Yen, S. Zhang, F. Bastani, Y. Zhang, A framework for IoT-based monitoring and diagnosis of manufacturing systems, in: *Proceedings – 11th IEEE International Symposium on Service-Oriented System Engineering, SOSE 2017*, 2017.
- [21] S. Tyagi, A. Agarwal, P. Maheshwari, A conceptual framework for IoT-based healthcare system using cloud computing, in: *Proceedings of the 2016 6th International Conference – Cloud System and Big Data Engineering, Confluence 2016*, 2016.
- [22] A. Nelson, G. Toth, D. Hoffman, C. Nguyen, S. Rhee, 2017, Towards a foundation for a collaborative replicable smart cities IoT architecture, in: *Proceedings of the 2nd International Workshop on Science of Smart City Operations and Platforms Engineering – SCOPE '17*.
- [23] S. Chakrabarty, D.W. Engels, A secure IoT architecture for smart cities, 2016 13th IEEE Annual Consumer Communications and Networking Conference, CCNC 2016, 2016.
- [24] Ji Zhanlin, I. Ganchev, M. O'Droma, 2014, A generic IoT architecture for smart cities, in: 25th IET Irish Signals Syst. Conf. 2014 2014 China. *Int. Conf. Inf. Communities Technol. (ISSC 2014/CICT 2014)*, pp. 196–199.
- [25] S. Shukla, K. Balachandran, V.S. Sumitha, K. Balachandran, V.S. Sumitha, A framework for smart transportation using big data, in: *Proc. 2016 Int. Conf. ICT Business, Ind. Gov. ICTBIG 2016*, pp. 1–3.
- [26] M. Leila, Z. Abdelhafid, D. Mahieddine, A new framework of authentication over cloud computing, *Advances in Intelligent Systems and Computing*, 2018.
- [27] N.M. Gonzalez, M.A.T. Rojas, M.V.M. Da Silva, F. Redigolo, T.C.M. De Brito Carvalho, C.C. Miers, M. Naslund, A.S. Ahmed, A framework for authentication and authorization credentials in cloud computing, in: *Proceedings – 12th IEEE International Conference on Trust, Security and Privacy in Computing and Communications, TrustCom 2013*, 2013.
- [28] R.K. Banyal, P. Jain, V.K. Jain, Multi-factor authentication framework for cloud computing, in: *Proceedings of International Conference on Computational Intelligence, Modelling and Simulation*, 2013.
- [29] C. Krupitzer, M. Breitbach, J. Saal, C. Becker, M. Segata, R. Lo Cigno, 2017, RoCoSys: a framework for coordination of mobile IoT devices, in: 2017 IEEE International Conference on Pervasive Computing and Communications Workshops, PerCom Workshops 2017.
- [30] J. Cecil, Internet of things (IoT)-based cyber-physical frameworks for advanced manufacturing and medicine, *Internet of Things and Data Analytics Handbook*, 2017.
- [31] R.A. Rojas, E. Rauch, R. Vidoni, D.T. Matt, Enabling connectivity of cyber-physical production systems: a conceptual framework, *Procedia Manuf.*, 2017.
- [32] K.M. Alam, A. El Saddik, C2PS: a digital twin architecture reference model for the cloud-based cyber-physical systems, *IEEE Access*, 2017.
- [33] L. Riliskis, E. Osipov, Maestro: an orchestration framework for large-scale WSN simulations, *Sensors (Switzerland)*, 2014.
- [34] P. Zheng, X. Xu, S. Yu, C. Liu, Personalized product configuration framework in an adaptable open architecture product platform, *J. Manuf. Syst.*, 2017.
- [35] P. Zheng, T.J. Lin, C.H. Chen, X. Xu, A systematic design approach for service innovation of smart product-service systems, *J. Clean. Prod.* 201 (November 2018) (2018) 657–667.
- [36] R. Zhong, Q. Dai, T. Qu, G. Hu, G. Huang, RFID-enabled real-time manufacturing execution system for mass-customization production, *Robot. Comput.* (2013).
- [37] P. Zheng, S. Yu, Y. Wang, R.Y. Zhong, X. Xu, User-experience based product development for mass personalization: a case study, *Procedia CIRP* (2017) 2–7.
- [38] M. Wang, M.S. Altaf, M. Al-Hussein, Y. Ma, Framework for an IoT-based shop floor material management system for panelized homebuilding, *Int. J. Constr. Manage.* 20 (2) (2018) 130–145.
- [39] Y. Kim, J. Nam, T. Park, S. Scott-Hayward, S. Shin, SODA: A Software-Defined Security Framework for IoT Environments, *Comput. Networks* 163 (2019) 106889.
- [40] B.H. Surya Mallika, V.V. Siva Rama Raju, Adaptive framework combining sensors and IoT for data monitoring in restricted areas, *Int. J. Innov. Technol. Explor. Eng.* 8(11) (2019) 564–567.
- [41] Y. Lu, J. Cecil, An internet of things (IoT)-based collaborative framework for advanced manufacturing, *Int. J. Adv. Manuf. Technol.* 84 (5–8) (2016) 1141–1152.
- [42] H. Mora, D. Gil, R.M. Terol, J. Azorin, J. Szymanski, An IoT-based computational framework for healthcare monitoring in mobile environments, *Sensors (Switzerland)* 17 (10) (2017).
- [43] L. Jiang, L.Da. Xu, H. Cai, Z. Jiang, F. Bu, B. Xu, An IoT-oriented data storage framework in cloud computing platform, *IEEE Trans. Ind. Informatics* 10 (2) (2014) 1443–1451.
- [44] C. Akasiadis, V. Pitsilis, C.D. Spyropoulos, A multi-protocol IoT platform based on open-source frameworks, *Sensors (Switzerland)* 19 (19) (2019) 1–25.
- [45] M. Ramalingam, R. Puviarasi, E. Chinnavan, H.K. Foong, Self-monitoring framework for patients in IoT-based healthcare system, *Int. J. Innov. Technol. Explor. Eng.* 8 (12) (2019) 3641–3645.
- [46] M. Tao, J. Zuo, Z. Liu, A. Castiglione, F. Palmieri, Multi-layer cloud architectural model and ontology-based security service framework for IoT-based smart homes, *Futur. Gener. Comput. Syst.* 78 (2018) 1040–1051.
- [47] S. Aheleroff, R.Y. Zhong, IoT-Enabled Personalisation for Smart Products and Services in the Context of Industry 4.0, 2018.
- [48] A. Lechler, A. Verl, Software Defined Manufacturing Extends Cloud-Based Control, *ASME 2017 12th Int. Manuf. Sci. Eng. Conf. MSEC 2017 collocated with JSME/ASME 2017 6th Int. Conf. Mater. Process.*, 2017, 3, pp. 1–6.
- [49] Z. Wen, X. Liu, Y. Xu, J. Zou, A RESTful framework for internet of things based on software defined network in modern manufacturing, *Int. J. Adv. Manuf. Technol.* 84 (1–4) (2016) 361–369.
- [50] Nayak, N.G., Durr, F., Rothermel, K., 2015, Software-defined environment for reconfigurable manufacturing systems, *Proc. – 2015 5th Int. Conf. Internet Things, IoT*, 2015, pp. 122–129.